

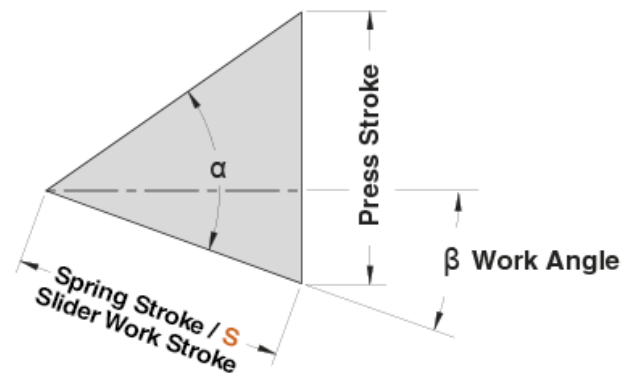

1. CAM DIAGRAM

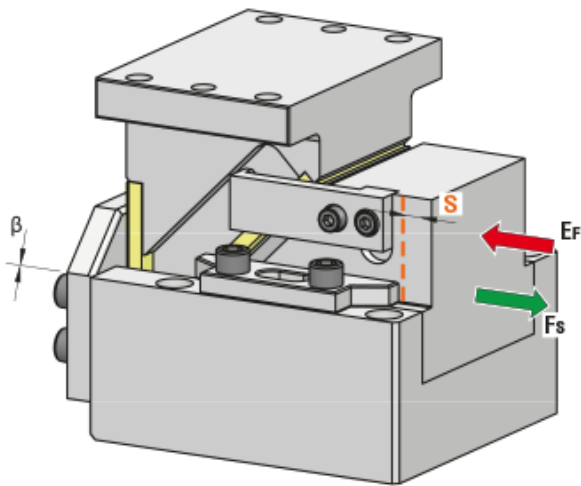

OMCR CODE	Work Angle β	Slider Work Stroke S (mm)	Press Stroke (mm)	Spring Stroke (mm)	$\alpha - \beta$	α
DHC100.00.40	0°	40	40	40	45°	45°
DHC100.00.60	0°	60	60	60	45°	45°
DHC100.00.80	0°	80	80	80	45°	45°
DHC100.05.45	5°	45	67,94	45	55°	60°
DHC100.05.70	5°	70	105,69	70	55°	60°
DHC100.10.45	10°	45	60,63	45	50°	60°
DHC100.10.70	10°	70	94,31	70	50°	60°
DHC100.15.45	15°	45	55,11	45	45°	60°
DHC100.15.70	15°	70	85,73	70	45°	60°
DHC100.20.45	20°	45	50,87	45	40°	60°
DHC100.20.70	20°	70	79,14	70	40°	60°

2. CAM WEIGHT INFORMATIONS

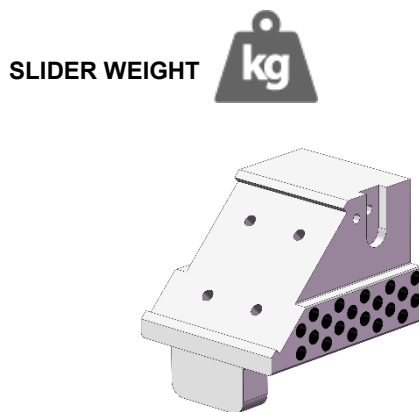
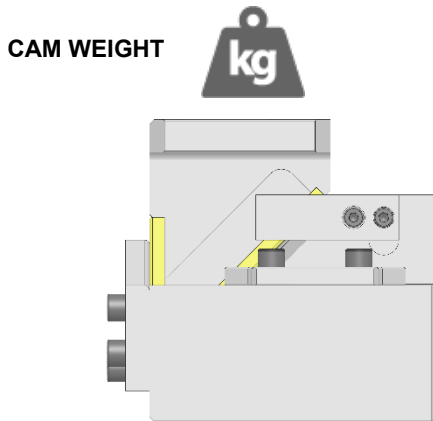

OMCR CODE	CAM WEIGHT [kg]	SLIDER WEIGHT [kg]
DHC100.00.40	32.303	7.801
DHC100.00.60	34.301	8.098
DHC100.00.80	38.760	10.011
DHC100.05.45	29.912	6.205
DHC100.05.70	36.195	7.484
DHC100.10.45	29.665	6.044
DHC100.10.70	35.957	7.071
DHC100.15.45	30.680	6.090
DHC100.15.70	36.991	7.330
DHC100.20.45	30.194	6.130
DHC100.20.70	37.108	7.214

3. CAM MOUNTING INFORMATIONS

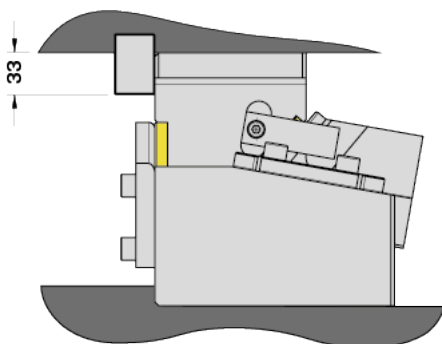

Assembly with shoulder
Max performances.

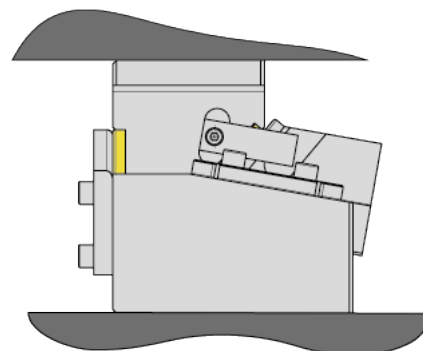

Assembly without shoulder
Compact installation.



2. WORK FORCE DISTRIBUTION (kN) FOR 1 MILLION CYCLES

The following diagrams illustrate the maximum possible ranges of applicable forces in several portions of the work area but always working in the exact direction of slider work stroke. If several forces are applied simultaneously on the work area, their common center has to be specified and compared with the tabular infos. The sum of all forces has to be lower than the corresponding tabular value.

F_s

Max Work Force with shoulder on Cam Driver

F

Max Work Force without shoulder

Assembly with shoulder

		WIDTH		
		33	34	33
$\beta = 0^\circ$				
HEIGHT	30	50	55	50
	30	53	75	53
	30	46	73	46

Assembly without shoulder

		WIDTH		
		33	34	33
$\beta = 0^\circ$				
HEIGHT	30	25	27	25
	30	26	38	26
	30	23	43	23

		WIDTH		
		33	34	33
$\beta > 0^\circ$				
HEIGHT	30	50	60	50
	30	53	82	53
	30	46	80	46

		WIDTH		
		33	34	33
$\beta > 0^\circ$				
HEIGHT	30	25	30	25
	30	26	41	26
	30	23	40	23